

JOWA USA

Chemtape™ Level Gauge for Chemicals

Features:

- Complete, intrinsically safe level gauging package for chemicals
- Hastelloy™ construction provides excellent chemical compatibility
- Tank top mounted for easy installation, stillpipe not required in non-agitated tanks
- Sensor has no moving parts to stick or break; virtually maintenance free
- Optional combined level and temperature capability; wide operating temperature
- Works with Wireless, WRT & WBR System

Description:

The Chemtape Gauging System is a cost effective solution for monitoring above or below ground storage tanks that are at or near atmospheric pressure. Gauged products include general industrial chemicals, pharmaceuticals, and petro-chemicals with temperatures up to 225°F (107°C).

Chemtape is a packaged system consisting of the unique resistance-tape sensor, a compact filter assembly, a sensor housing and a two-wire 4-20mA current transmitter. It is available in overall lengths of 3 to 100 feet (1 to 30 meters). The filter assembly protects the sensor from moisture and contaminants and provides pressure equalization. The stainless steel sensor housing mounts to a 3 inch flange.

Excitation required is nominal 24VDC and the system is intrinsically safe with the use of FM approved zener barriers. Chemtape offers the option of adding one temperature detector and corresponding 4-20mA output for monitoring temperature.

Chemtape can also be installed with our wireless transceiver, model WRT, completely eliminating the need to run wire to the sensor.

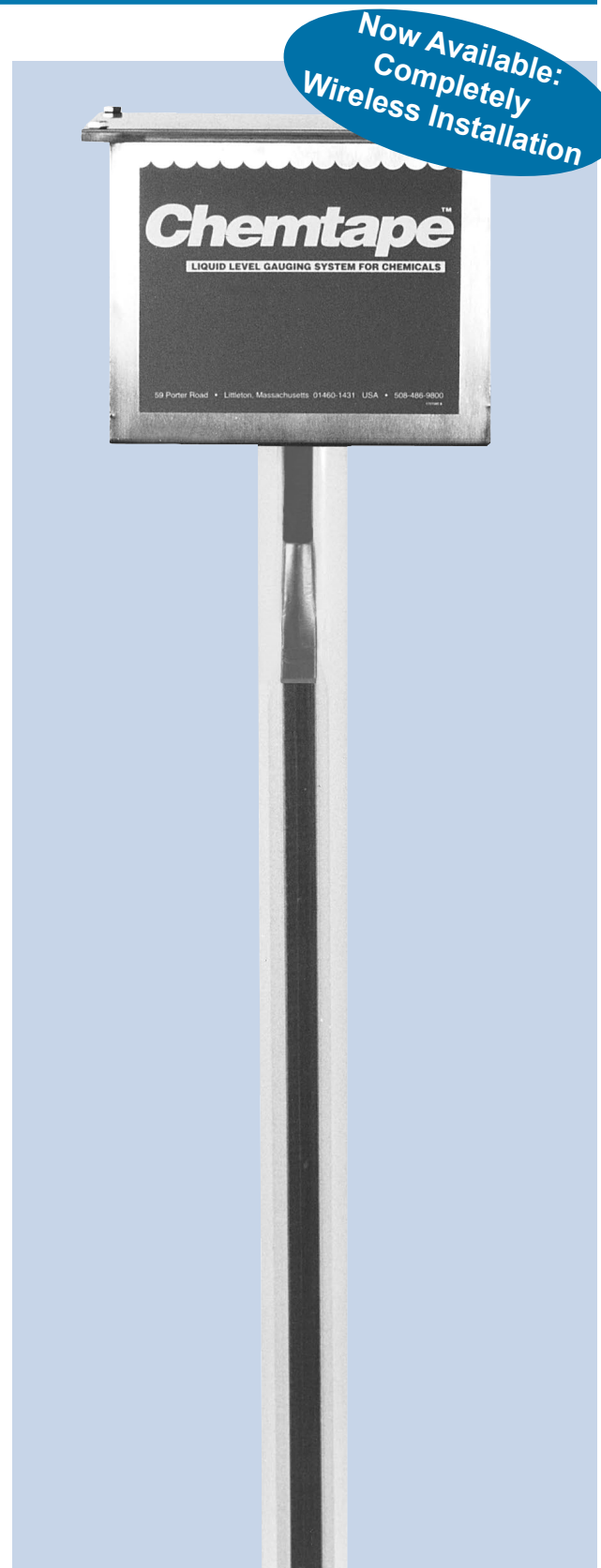

Chemtape™ Level Gauge for Chemicals

Operation Principle:

The resistance-tape sensor's outer envelope jacket (1), is compressed by hydrostatic pressure causing the gold plated nichrome wire helix to contact the stainless steel base strip (2). The resulting resistance (3) indicates the length of active or uncontacted helix, and the distance from sensor top to liquid surface.

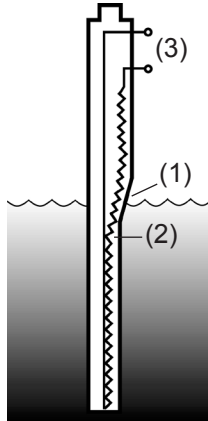

Installation:

The sensor can be installed into a customer supplied, vented stillpipe with a minimum diameter of 1.5 inches. Specific stillpipe construction may vary with application. For non-agitated applications a weight may be affixed to the back side of the sensor eliminating the need for a stillpipe. Contact the factory for additional details.

To Specify Length - (1) Select sensor length that is greater than height of tank, generally 1 foot greater; (2) Make stillpipe the same height as the sensor, $LS = LP$, and stillpipe will extend beyond the sensor by 1 3/4 inches (45mm), the height of close nipple.

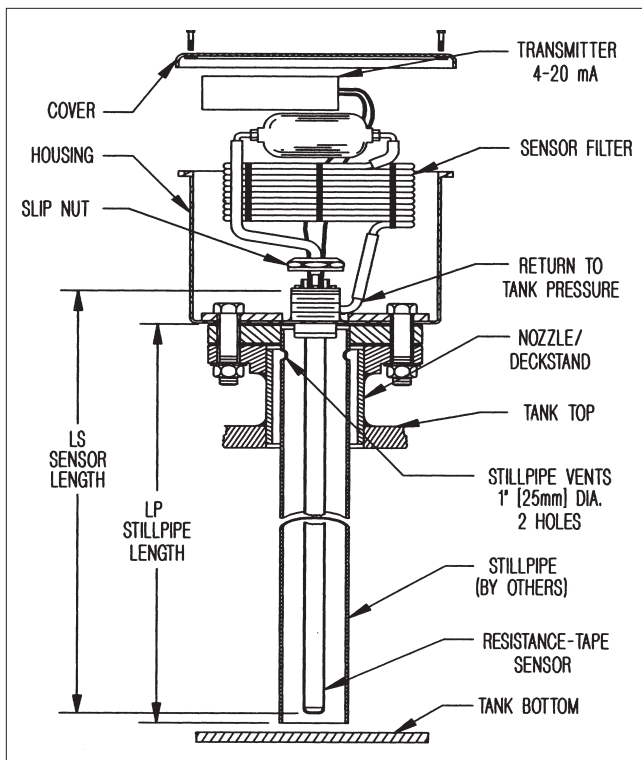

Disclaimer:

This is not a specification and all information is provided in good faith. Since conditions of use are beyond the control of JOWA USA, Inc., the information contained herein is without warranty, whether express, implied or otherwise. Final determination as to the suitability, merchantability or fitness of any information, material or product for a particular purpose, or any patent infringement, is the sole responsibility of the user. JOWA USA, Inc. does not assume liability for injury arising from the use of the information, material or product, and assumes no liability for any damages, whether direct, indirect, consequential, special, incidental, punitive or otherwise. For additional information regarding JOWA USA, Inc.'s limited warranty, refer to the Terms and Conditions that are currently in effect.

Specifications:

Sensor Overall Length: 3 to 100 feet or 1 to 30 meters.

Operating Temperature: 5° to 225°F (-15° to 107°C).

Wetted Materials: Hastelloy C276, 303 Stainless Steel, Glass-filled Polypropylene or optional 316 Stainless Steel Channel. Slip nut is chrome-plated brass.

Active Helix: Starts 9.09 in. (230 mm) from sensor zero, extends to approx. 1.6 in. (40 mm) from sensor bottom.

Helix Resolution: 1/4 inch (5 mm).

Actuation Depth: Nominal 7 inch (180 mm) head of water, offset at calibration.

Specific Gravity Effect: 1% increase in SG causes nominal .07 in. (1.8 mm) increase in indicated level, (can be calibrated).

Resistance Gradient: 305Ω/ft (1000Ω/m), ± 1.5%.

Helix Temperature Coefficient: 40 ppm/°C.

Frequency Response: 0 to 0.1 Hz at 1 m amplitude.

Sensor Filter: Polypropylene and viton construction. Filter life of 24 to 48 months, varies with application and level cycle activity.

Pressure Equalization: Direct equalization ± 2 PSI.

Sensor Housing: 304 Stainless Steel, 8 x 8 x 7 in. (203 x 203 x 178 mm), punched for 3 inch, 125/150 lb. flange.

T-800 Series Current Transmitter: Compact, two-wire, 4-20mA innage output. Receives nominal 24VDC excitation from others. Span and Zero adjusted by internal DIP switches and potentiometers. Transmitter stability is ± 0.001%/°F.

Approvals: When used with approved zener barrier, system is intrinsically safe. FM: Class I, Division 1, Groups C, D. Transmitter FM Entity Parameters: (level only): $V_{max} = 32$ VDC, $I_{max} = 120$ mA, $C_i = 0.24$ mfd, $L_i = 0.0$ mH.

Temperature Detector (Option): One, two-wire RTD, 1000 ohm platinum. Located 2.0 ft (.6 m) from bottom.

Sensor Shipment/Storage: Weight: 22 lb (10 kg), plus 0.4 lb/ft (0.6 kg/m). Lengths to 3 feet (1 meter) may be in rigid tube. Longer sensors are coiled on paperboard reel and packed in corrugated box 42 x 42 x 3 in. (107 x 107 x 8 cm). Packing adds 8 lbs (3.63 kg) to sensor weight.



JOWA USA, Inc.

59 Porter Road

Littleton, MA 01460-1431 USA

Tel: 978-486-9800 Toll free: 800-861-1560

Fax: 978-486-0170 E-mail: info@jowa-usa.com

www.jowa-usa.com